

The product line of development boards LDM-FLEX10Kxx-T144 is a printed circuit board, size 114x79x12 mm and prototypical field 78x52 mm (hole pitch 2.54 mm) with installed chip FPGA DD1 of Altera company a family of FLEX 10K FPGA in the housing TQFP-144. For the convenience of the design the board under the chip DD1 is traced so that it is convenient to solder by wiring (pin in/out have appropriate areas, provided by the housing DD1, refer to pin numbers are shown in Fig. 4). The development board has a connector XS2 (IDC-10MS) to connect a download cable LDM-USB-Blaster, LDM-PB 2.01 ByteBlasterMV or its analogs (in the mode PS-MODE). Power can be carried out by an external stabilized source with the voltage + 9 ... 12 V that is connected to the connector XS1. LED VD2 is a power indicator.



Fig. 1. General view of the development board.

Linear voltage converter DA1 (LM317D2P) in the housing D2PAK transforms supply voltage to the voltage $VCC = 3.3\text{ V}$ or $VCC = 5.0\text{ V}$, it depends on the type of FPGA (Tab. 1).

Main characteristics of the development board.

Board Edition	Type of FPGA	Voltage FPGA, V	Number pins in/out	Logic capacity of logic cells
LDM-FLEX10K10A-T144	EPF10K10ATC144	3.3	102	10 000
LDM-FLEX10K10-T144	EPF10K10TC144	5.0	102	10 000
LDM-FLEX10K20-T144	EPF10K20TC144	5.0	102	20 000

The board provides mounting platform for installation of chip configuration DD2 (EPC2LC20) in the housing PLCC-20. Connector XS3 (IDC-10MS) is intended for connection a download cable LDM-PB 2.01 ByteBlasterMV (in the mode JTAG) and for loading configuration data. In the programming mode of DD2 jumpers JP1-JP5 should be switched off.

The development board is intended for prototyping devices designed on FPGA of the company Altera a family of FLEX 10K, and also for assembly completed devices by mounting necessary components on the prototypical field of the board. Use of LDM-FLEX10Kxx allows minimizing the implementation time of the product on the market.

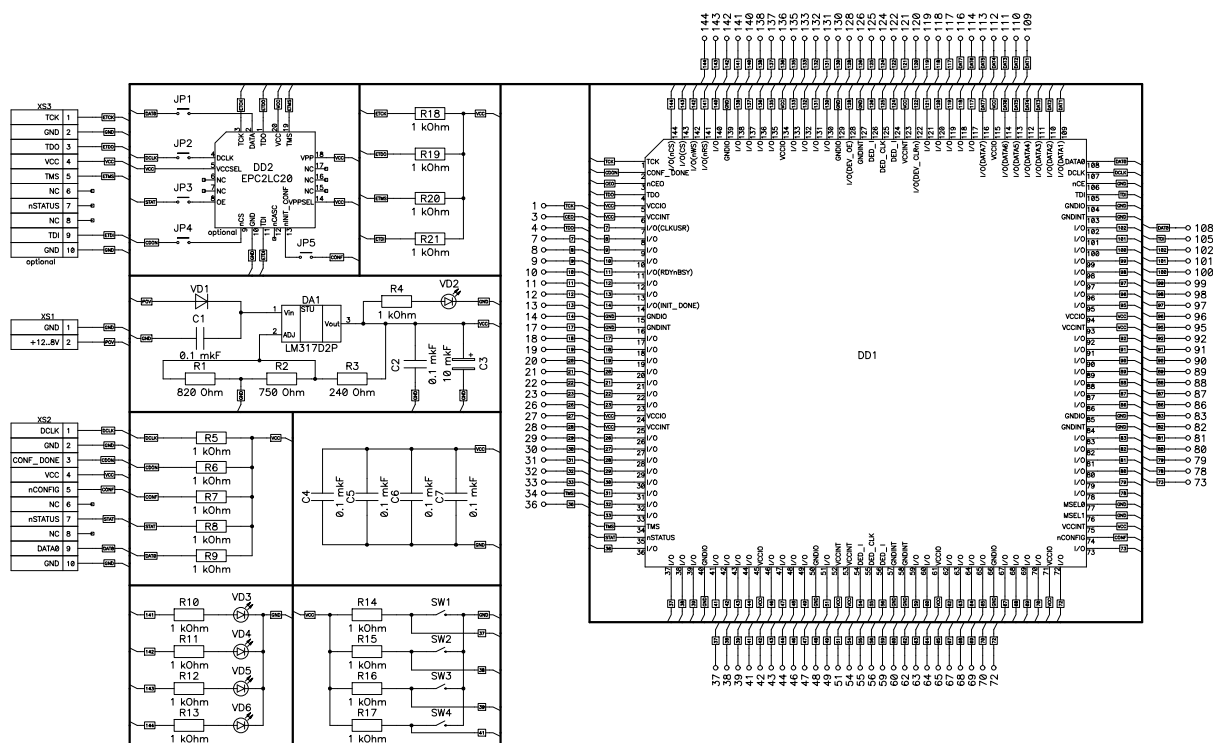

Fig. 2. The electrical scheme.

There are four LEDs VD3-VD6 and four buttons SW1-SW4 on the board which are connected with FPGA. It is intended for simplification of designing and can be useful during the test of project.

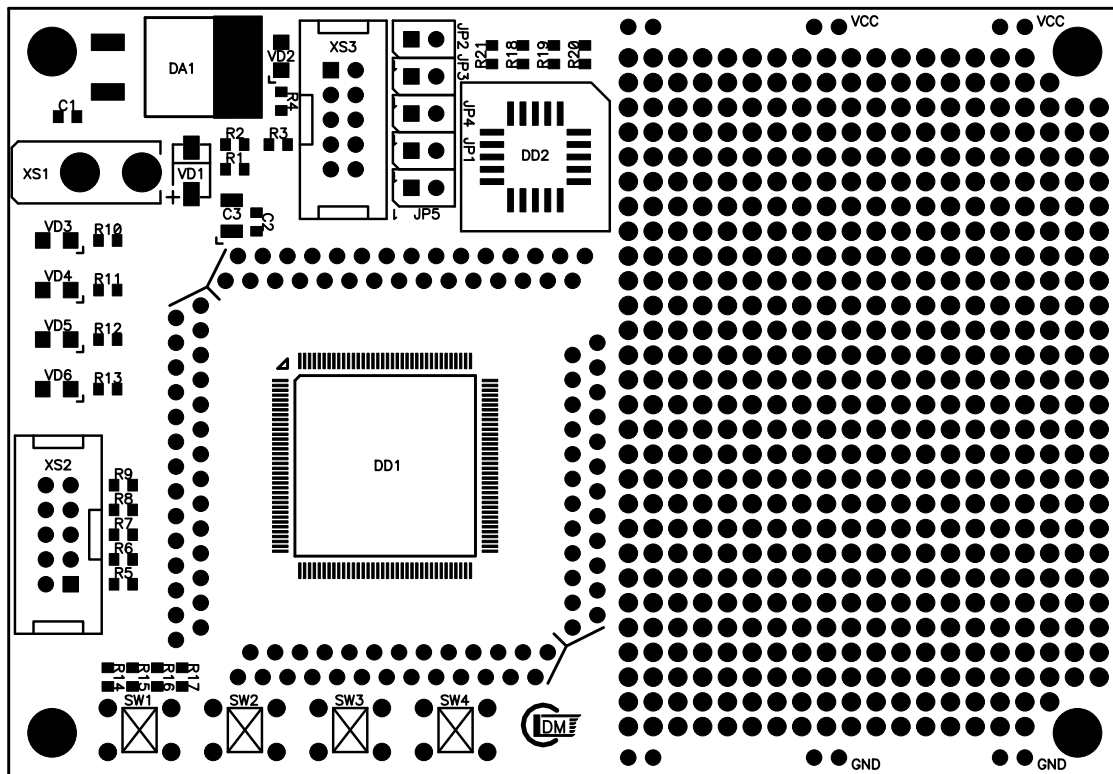

Fig. 3. External view of the printing board.

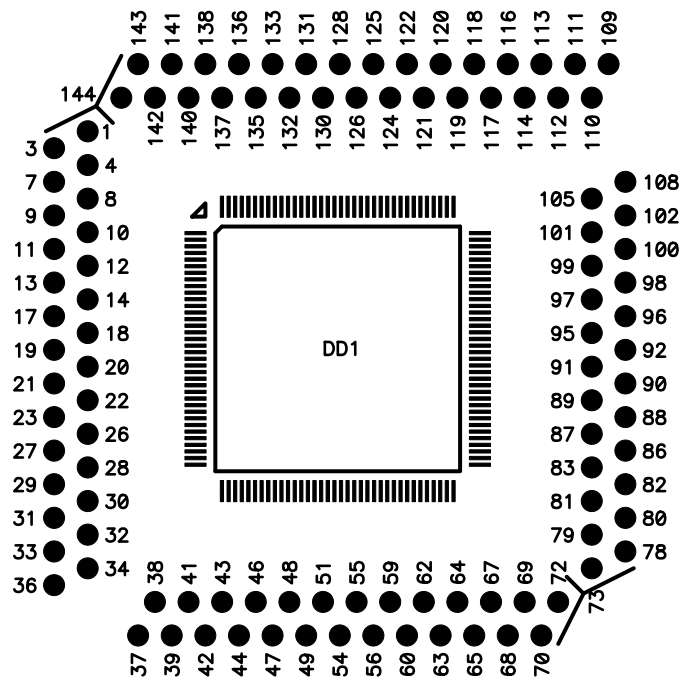

Fig. 4. Designation of mounting pads.

Packaging arrangements:

- The development board;
- Description of the development board;
- Examples of projects for Quartus II Web Edition Software;
- Description of the family of FPGA Altera.